

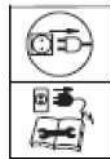

**Instruction Manual of deep-well pumps of type:
3SDm, 3SD, 3ti, 3t2i, 3SKm, 4SKm, 4SCR, 4SD, 4SDm,
3.5"SCM, 3.5"SCR, 90MSC, 3"SQIBO, STING, DWP, 3"SCR, 4"ISP, 6"ISP,
4"ISPm, 4"SCR, OLA, 2,5"STm, 3STm**



reading the instruction manual is obligatory



electrocution hazard



device damage hazard



NOTE: read the manual prior to commencement of use. For safety reasons, the pump can only be operated by persons well-familiarised.



NOTE: the manual is a primary part of the purchase and sale contract. The user's failure to observe the instructions included in the manual is a breach of the contract and excludes any complaints arising from potential device failure caused by the use that is inconsistent with instructions of its use.



NOTE: failure to observe the instructions included in the manual can result in hazard for persons, properties in which they are installed, environment and the pump itself.



CAUTION! This equipment is not intended for use by persons (including children) with reduced motor, sensory or mental capacities, or persons without experience or not familiarised with the equipment, unless it is performed under supervision

or according to the instruction regarding operation provided by persons responsible for their safety.

Attention should be paid so that children do not play with the equipment.

APPLICATION:

The pumps referred to in the manual are intended for pumping clean water from bored deep water intakes or increasing pressure in water systems with the enclosure of the aggregate in a hermetic jacket.

They can be used in households as water supply, means of irrigation, in heat pump installations, and to feed water into industrial installations. The pumped water cannot contain any mechanical contamination.





The pump is intended for pumping of clean water, with no solid- abrasive particles. Pumping water containing sand results in fast wear and tear of the pump and, in consequence, its failure. In such a case, only paid repair is available. The above not refers to the pumps with increased resistance to sand.

For these pumps the maximal sand content in water cannot exceed 5%. It must be remembered that even the life of pumps with increased resistance against sand will be significantly shorter when the pump will pump water with sand contamination. The wear and tear of elements that pump sand is not subject to warranty repair. This is regarded as operating wear and tear.

 The pump is not adjusted to pump caustic, flammable, destructive or explosive substances (e.g. petrol, nitro, oil, etc.), foodstuffs or salty water. Failure caused by pumping of the same type of liquid is not subject to warranty repair.

 The maximal temperature of the pumped water is 35°C.

 The pump is not adjusted to pump water containing excessive amounts of mineral elements causing deposition of scale on the pumping elements. The use of the pump in such conditions results in premature wear and tear of the operating elements of the pump. In such a case, only paid repair of the pump is available.

 The pump cannot pump water containing oils and petroleum derivatives. The pump operation in such water can lead to destruction of rubber elements, e.g. cables or sealing, and result in leakage in the pump and motor failure. In such a case, only paid repair of the pump is available.

 Pumped water cannot contain any long-fibrous contamination.

PUMP INSTALLATION:

 Prior to any installation works, power supply must be disconnected. Provide security against accidental switch-on. Pumps 3ti, 3t2i, 3SDm, 4SD i 4SDm, 4ISP, 4ISPM, 6ISP, 3STm due to their dimensions can be delivered in two elements. One element is a hydraulic part of the pump, the other is a motor. Prior to connection of two elements, the clamping screws must be unscrewed from the strip protecting the cable. Next, the screws clamping the strainer must be unscrewed and the strainer removed. The clamping nuts with washers must be unscrewed and removed. When the motor is placed in a vertical position, the hydraulic element must be mounted on the motor shaft ended with splines is placed in the clutch of the pump. If, in the course of mounting, there are any difficulties with coupling, the motor shaft must be turned to make the splines match the motor clutch. A hydraulic element, correctly mounted on the motor, is fully supported by the top bearing body of the motor. The aggregate prepared in this manner can be screwed with screw nuts and washers. Screw nuts must be tightened crosswise. The minimal moment of tightening screw nuts for motors 4" is 18 Nm.

 If the screws are not tightened accurately, it can result in their unscrewing on operation and motor "sinking" in the borehole. Upon installation of hydraulic element on the motor, placing the power supply cable on the pump, the strainer must be installed and screwed prior to the installation of the strip protecting the cable.

 The lowering of the pump into the borehole without a surge protector can result in destruction of cable isolation which can be the cause of pump failure or electrocution of the operators.

 For pumps SD, SDm, SCM, ISPM, ISP, STm, due to the necessity to ensure motor cooling on operation, the diameter of a borehole where the pump operates cannot exceed the values presented in the table below. The values are in mm. The diameters are consistent with the pump efficiency.

2 m ³ /h	4 m ³ /h	5 m ³ /h	7 m ³ /h	10 m ³ /h	15 m ³ /h	20 m ³ /h	25 m ³ /h	30 m ³ /h	40 m ³ /h
102 mm	103 mm	115 mm	160 mm	195 mm	240 mm	285 mm	320 mm	350 mm	410 mm

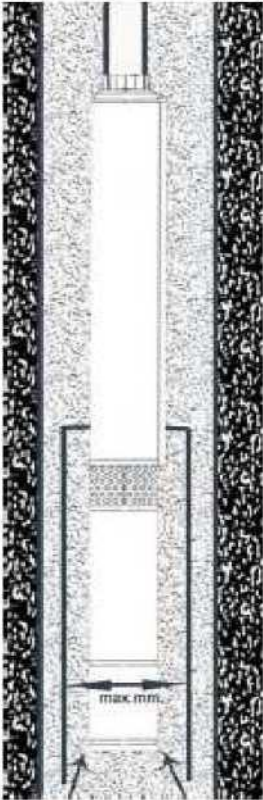

⚠ The use of the pump in a well with wider diameter than shown in the table can result in motor overheating and its failure. If the well in which the pump is to operate has wider diameter than specified in the table, the pump must be installed in a special jacket forcing the proper cooling. In pic. the idea of such a jacket is presented.

⚠ The pump must be installed in the well section above the filter. The minimal distance between the upper edge of the top part of the well filter and the bottom edge of the motor cannot be smaller than 30 cm. The use of the pump installed nearer to the bottom can result in sand suction which, in turn, can lead to faster wear and tear of pumping elements. If the pump is placed in sludge, it can result in motor overheating.

⚠ The Pump cannot operate “dry” without water. “Dry” operation can lead to device damage. In such a case, only paid repair is available.

In order to avoid potential dry operation, the pump must be installed at such a depth so that the lowest, dynamic mirror level (the mirror level set at the time of constant pumping with slow inflow) was at least 2 m above the discharge port.

such installation (the well is not efficient enough in relation to pump

efficiency), then you can choose one of the following solutions:

- install a valve on the pumping pipeline that will constantly limit the flow,
- install a security device protecting against dry operation, monitoring the water mirror level which in case of dry operation hazard will switch off power supply to the aggregate.

⚠ When lowering the pump into the well, attention must be paid that the supply cable of the pump is fixed to the supply pipe with plastic bands in spans not exceeding 2 m. In case of significant depth of pump installation, the cable which is not attached to the delivery pipeline can, due to its weight, be broken.

⚠ It is also recommended that the pump is suspended on a steel line so that if the delivery pipeline gets unscrewed, the aggregate does not sink in the well.

⚠ The check valve protecting the device against impacts of returning water must be installed directly above the pump.

⚠ The pump motor is filled with ecological oil. In case of motor failure, the oil can leak into the well.



Prior to lowering of the pump into a new well, a user should ensure that the well company that manufactured the well performed its purification by pumping out water. On well construction the water inside the casing pipe and filter is contaminated with sludge and sand.

Pumping water with sand contamination significantly shortens the life of borehole pumps.



While setting the pressure switch and selecting the hydrophoric tank, the following rule must be observed: the pump motor cannot be switched on more than 30 times an hour. More frequent switching on can lead to motor overload and failure, or pump failure.

ELECTRIC CONNECTION:

The electric network used to power the pump must be compliant with data provided on the rating plate.

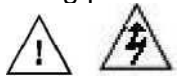

The pump must be connected to a network with active earthing.

The manufacturer and guarantor are not liable for any damage to people or property resulting from lack of proper earthing.

The yellow-green core of the connection cable is earthing.



The powering network must be equipped with an installation, overcurrent motor circuit breaker in e.g. M611, securing the motor against overload. In order to provide maximum overload protection for the motor, the switch must be set to maximum coil current provided on the rating plate.



The device can operate without this protection, but in case of a failure caused by overload, the repair costs are incurred by the user.



The powering installation of the pump must be equipped with a residual current device, with rated making current ΔI_n not exceeding 30 mA. The manufacturer and guarantor are not liable for any damage to people or property resulting from supplying the pump with power without a proper switch.



It is forbidden that there are present people or animals in the water where the pump works.



In case of cable insulation destruction, the pump use is forbidden. In such a case, it is necessary to contact the guarantor with the purpose of cable replacement. Mechanical damages are not subject to warranty repairs that are free of charge. The use of the pump with damaged cable insulation, in the best case scenario, will lead to motor flooding with water, whereas, in the worst case scenario, it can result in electrocution.



Prior to pump launch, the voltage at the end of the cable must be checked. It must be remembered that the longer the cable, the lower the supply voltage at its end. Admissible voltage drops for applied motors are $\pm 6\%$.

In order to avoid excessive drop in voltage, the length of the cable must be properly selected depending on the type of power supply (one or three-phase), motor power, cable length. The table below facilitates the proper selection of the cable:

		The maximum, acceptable cable length dependent on the diameter of cable cores of the power supply cable						
Type of power supply	Power of the supplied motor [kW]	1 mm ²	1.5 mm ²	2.5 mm ²	4 mm ²	6 mm ²	10 mm ²	16 mm ²
1x230 V	0.37	50	75	125				
1x230 V	0.55	40	58	94	150			
1x230 V	0.75	30	46	74	121	174		
1x230 V	1.1	21	32	50	86	125	215	
1x230 V	1.5		22	37	62	90	155	245
1x230 V	2.2			30	45	67	115	180
3x400 V	0.75	135	200	235				
3x400 V	1.1	98	145	245	390			
3x400 V	1.5	75	110	180	290	435		
3x400 V	2.2	52	80	130	210	310	515	
3x400 V	3	40	60	105	170	250	415	
3x400 V	4	30	48	80	125	190	310	495
3x400 V	5.5		35	60	90	135	225	360
3x400 V	7.5			55	85	125	210	325



Not following the above instructions on cable selection can lead to pump operation with too low voltage and consequent motor overload which can result in failure.



If the manufacturer equipped the pump with a short cable, then, it can be extended according to the user needs. The hermetic connection of the cables should be performed by a person with adequate knowledge and experience. The user should assign such installation to a well fitter, or they can do it in the shop of the well purchase. Unprofessional connection and insulation of the cables can lead to automatic trigger of the residual-current devices, flooding motor with water or electrocution of the user. Cable extension in types of pump equipped with launching cable box may require its disassembly. Prior to disassembly, it is recommended to check the connection of cable cores in the cable box and connect the cable cores of the extension cable in the same way. Incorrect connection can lead to motor failure, pump failure, pump operation with lowered parameters. It is recommended that the extension of the power supply cable is assigned to the guarantor or well fitter.

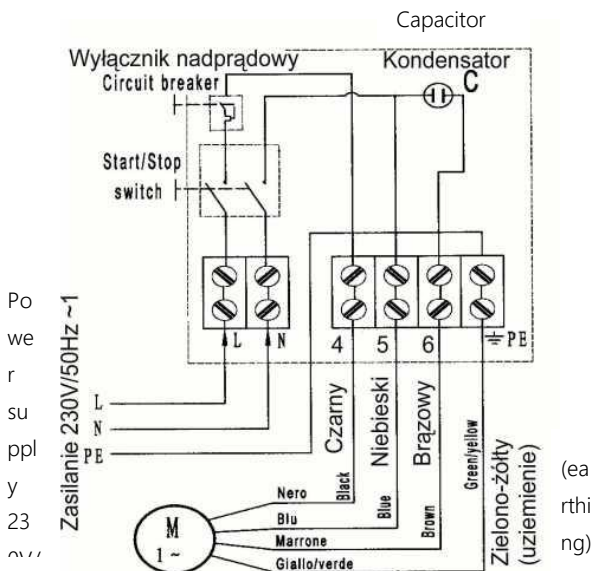

The cable box is separately delivered to some types of pumps. There is a starting capacitor built in the cable box as well as an overcurrent protection, switch. The picture presents the diagram of cable core connection of the power supply cable to the connecting strip in the box. Cable cores of the power supply cable are marked with small tags with core no. When identifying cores with tags or colour, connect them according to the diagram.

PUMP MATCHING WITH POWER GENERATOR:

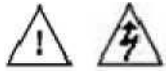

The power of the rated current of the power generator, due to its high starting current, should be 3 to 5 times higher than the rated current power of the supplied motor.



On pump launch the following rule must be observed: the pump can only be connected upon the power generator launch. If the aggregate is switched on with a connected pump, it can lead to burning of the pump motor. In such a case, only paid repair is available.

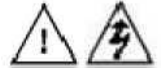

Switch off the pump should be performed in this order:

First the pump must be disconnected, and then the aggregate can be switched off. Switching off the aggregate with a connected pump can result in pump motor getting burnt. In such a case, only paid repair is available.

STORAGE:

The cleaned pump must be stored in a dry room.

Attention must be paid so that the whole length of the pump is placed on an even surface. Supporting pump in one or more points can lead to pump deflection which can result in failure.

DEVICE DISPOSAL:



the used product is subject to disposal as wastes only in selective waste collection systems organised by the Network of Communal Electric and Electronic Waste Collection Centres. the customer is entitled to return the used equipment to the network of the electric equipment distributor, at least for free and directly, if the returned device is of proper type and fulfils the same function as a newly purchased device.

EC DECLARATION OF CONFORMITY (Module A):

PHU DAMBAT address: Gawartowa Wola 38, 05-085 KAMPINOS

Under the Act of 30 August 2002 on the conformity system (Journal of Laws of 2004, No. 204 item 2087) we declare with full responsibility that pumps included in the series 3SDm, 3SD, 3ti, 3t2i, 3SKm, 4SKm, 4SCR, 4SD, 4SDm, 3,5”SCM, 3,5”SCR, 90MSC, 4SKt, 3SQIBO, DWP, STING, SPm, SP, 3”SCR, 4ISP,6ISP,4ISPM, FL, OLA, STm to which this declaration refers to are consistent with the following guidelines of the Council on legal regulations unification in member states of EC:

- 1) MD 2006/42/EC (applied standards EN 292-1:1991, EN 292-2-1991/A1: 1995, PN-EN 809:1999/AC: 2004)
- 2) EMC 2004/108/EC (applied standards PN-EN 55014-1:2004, PN-EN 61000-3-2:2004)
- 3) LVD 2014/35/EU (applied standards, PN EN 60335-1:2012, PN EN 60335-2-41:2012)

Adam Jastrzębski

02.10.2017

POSSIBLE OPERATION PROBLEMS AND TROUBLESHOOTING

Sign:	Possible cause:	Problem solution:
The pump does not operate	Security device protecting against dry operation triggered	Wait until the water amount in the well is sufficient for automatic pump launch.
	Overcurrent security device triggered	Check if there is an overload. Remove the cause. Wait until the motor cools down and switch on the pump by means of the switch built in the protecting cable box.

	No power supply	Check if the electric plug of the pump is properly inserted into the electric socket.
		Check fuses at home and all other types of installation fuses that can cut off the power supply from the network
		Check if there is a power supply in your neighbourhood - power can be cut off by the power plant in the larger area
	Incorrect voltage or its drop on launch	Check the voltage Check if the cable cross-section is sufficient.
Pump operates but does not feed water or feeds too little	Blocked strained at suction	Disconnect the pump from power supply. Upon pump removal from the well clean the filter
	Incorrect direction of motor rotation	Change two core cables of power supply cable in the supply strip (only in case of three-phase motors).
		Incorrect connection of core cables in the cable box (only if they were disconnected by the user). Connect them in a correct manner. Assign the correct connection to the service.
	Too high resistance at flow through the pumping pipeline (hose).	Check if the maximal value of lifting for the said pump type was not exceeded. The difference between the level of the water mirror in the well from which the water is pumped, the level onto which the water is pumped, the length of the pumping pipeline (hose) and its diameter are factors which influence the height of lifting that must be performed by the pump. If the resistance is too high for the said pump type, replace the pump with another one with greater lifting height.
	Sand in the pump (water with sand contamination)	Remove sand from the pump Clean the well. The pump is installed too close to the well bottom. Pump sucks in sand.
	Too low supply voltage	Check the supply voltage
	Not enough water in the well	Check the pump position. The discharge port should be placed at least 2 m above the lowest dynamic water mirror level.
	Water contamination with sand	Worn and torn subassemblies pump water. The pump is installed too close to the well bottom. Pump sucks in sand. Assign paid replacement of worn and torn elements to the guarantee service
Frequent switching on and switching off the pump Frequent switching on and switching off the pump	Hydrophoric tank is too small	Replace the tank with a bigger one
	There is no air cushion in the tank	Check air pressure in the tank Pump in more. If the situation often repeats, check if the tank membrane is not broken
	The difference between the switch-on and switch-off pressure on the pressure switch is too small	Readjust the switch
	Suspended check valve	Remove the pump, replace the valve.

